

## MVE Cryoshipper mini

with insert blocks

Custom configured cabosil inserts maximize holding times for small sample shipments.

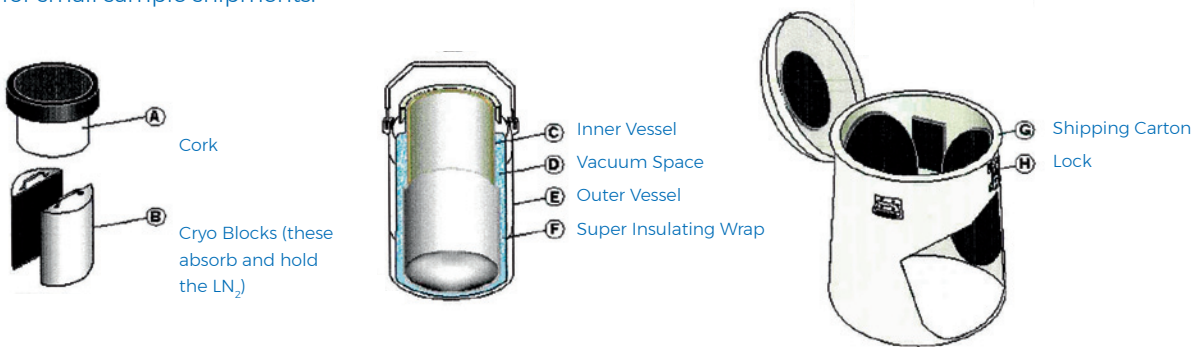

### PRODUCT SPECIFICATIONS

PARAMETER	SPECIFICATION
Neck opening	8.5"
Cavity size	8.5 x 2 x 10"
Overall height	20"
Outside diameter	11.875"
Weight empty (no blocks)	16.5 lbs
Weight of charged unit	34.25 lbs
Shipping carton weight	10.91 lbs
Shipping carton dimensions	24" high, OD 14"
LN <sub>2</sub> capacity	5.9 L
Static Evaporation Rate	0.84 L/Day
Static Hold Time	7 Days

### CRYO BLOCKS - SAMPLE HOLD TIME

(Approximate when Block Are Fully Charged)



### CRYO BLOCKS - APPROXIMATE SAMPLE CAPACITY



### CRYO BLOCKS - MIX AND MATCH

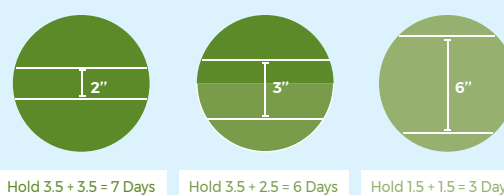

Hold 3.5 + 3.5 = 7 Days

Hold 3.5 + 2.5 = 6 Days

Hold 1.5 + 1.5 = 3 Days

Choose blocks to match sample volume and hold times as required by customer. NB // Part Numbers are for 1 block, not a pair.

\* Hold times are approximate when full charged